

Shear Couplings

Features

- Integral square key prevents shear of pins in torsion
- Ideal for insert, tubing and progressing cavity pumps*
- 4340 HTSR construction for durability and long life

Material Specifications

Coupling: 4340 HTSR

Shear Pin: ANSI W1

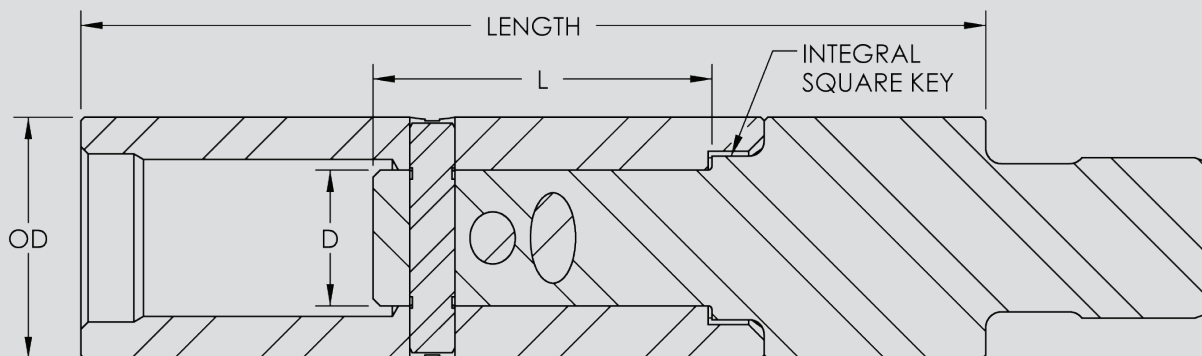

Typical API Grade D Sucker Rod Reference Information

ROD SIZE (IN)	MAXIMUM TORQUE (FT-LB)	MAXIMUM TENSILE LOAD (LB)
3/4	460	35,780
7/8	735	48,700
1	1,100	63,625
1- 1/8	1,570	80,500

Tensile load values derived from API 11B, and are for reference only.
 Torque values are typical from rod manufacturer and are for reference only.
 Consult rod manufacturer for specifications regarding load and torque.

* For deviated horizontal, and problem wells, Plainsman recommends referring to the proven designed ToughTorq™ Shear Coupling brochure

SHEAR COUPLINGS



SIZE (PIN & BOX) (IN)	OD (IN)	LENGTH (IN)	SHEAR STRENGTH (LB)	"L" ⁴ (IN)	"D" ⁴ (IN)	MAXIMUM ALLOWABLE STATIC TORQUE ³ (LB-FT)	PINS	
							#	COLOUR
3/4	1.63	7.00	14,000	2.80	1.13	1,500	2	Green
			19,000	2.80	1.13		2	Red
			22,000	2.80	1.13		2	Yellow
			26,000	2.80	1.13		2	Black
			30,000	2.80	1.13		2	White
			35,000	2.80	1.13		3	Black & White
			40,000	2.80	1.13		3	Blue
7/8	1.63 ¹	7.25	14,000	2.80	1.13	1,500	2	Green
			19,000	2.80	1.13		2	Red
			22,000	2.80	1.13		2	Yellow
			26,000	2.80	1.13		2	Black
			30,000	2.80	1.13		2	White
			35,000	2.80	1.13		3	Black & White
			40,000	2.80	1.13		3	Blue
		8.00	50,000	3.31	1.13		4	Blue & Yellow
	1	2.00 ¹	7.50	30,000	2.80	1.13	2,000	2
35,000				2.80	1.13	3		Black & White
40,000				2.80	1.13	3		Blue
45,000				2.80	1.13	3		White
8.00			50,000	3.31	1.13	4		Yellow
1-1/8	2.38	8.50	35,000 ²	3.25	1.50	3,750	3	Black & White
			40,000	3.25	1.50		3	Blue
			45,000 ²	3.25	1.50		3	White
			50,000	3.25	1.50		4	Blue & Yellow
			60,000 ²	3.25	1.50		4	White

1. Slimhole coupling diameter
2. Available in ToughTorq™ configuration only (Box x Box)
3. To maximize fatigue life, Plainsman recommends using a .8 service factor
4. Customer-driven request for well fishing applications

Note: For torsional applications, place coupling in straight section of well, minimum of 1-2 rods above rotor, with centralizing couplings

MADE IN CANADA

